



# AGENDA

Lake Park Town Commission  
Town of Lake Park, Florida  
Regular Commission Meeting  
Wednesday, December 7, 2016,  
Immediately Following the  
CRA Board Meeting,  
Lake Park Town Hall  
535 Park Avenue

<b>James DuBois</b>	—	<b>Mayor</b>
<b>Kimberly Glas-Castro</b>	—	<b>Vice-Mayor</b>
<b>Erin T. Flaherty</b>	—	<b>Commissioner</b>
<b>Anne Lynch</b>	—	<b>Commissioner</b>
<b>Michael O'Rourke</b>	—	<b>Commissioner</b>
<hr/>		
<b>John O. D'Agostino</b>	—	<b>Town Manager</b>
<b>Thomas J. Baird, Esq.</b>	—	<b>Town Attorney</b>
<b>Vivian Mendez, CMC</b>	—	<b>Town Clerk</b>

PLEASE TAKE NOTICE AND BE ADVISED, that if any interested person desires to appeal any decision of the Town Commission, with respect to any matter considered at this meeting, such interested person will need a record of the proceedings, and for such purpose, may need to ensure that a verbatim record of the proceedings is made, which record includes the testimony and evidence upon which the appeal is to be based. *Persons with disabilities requiring accommodations in order to participate in the meeting should contact the Town Clerk's office by calling 881-3311 at least 48 hours in advance to request accommodations.*

A. CALL TO ORDER/ROLL CALL

B. PLEDGE OF ALLEGIANCE

C. SPECIAL PRESENTATIONS/REPORTS

None

D. PUBLIC COMMENT:

This time is provided for addressing items that do not appear on the Agenda. Please complete a comment card and provide it to the Town Clerk so speakers may be announced. Please remember comments are limited to a TOTAL of three minutes.

E. CONSENT AGENDA: All matters listed under this item are considered routine and action will be taken by one motion. There will be no separate discussion of these items unless a Commissioner or person so requests, in which event the item will be removed from the general order of business and considered in its normal

sequence on the agenda. Any person wishing to speak on an agenda item is asked to complete a public comment card located on either side of the Chambers and given to the Town Clerk. Cards must be submitted before the item is discussed.

1. Regular Commission Meeting Minutes of November 16, 2016 Tab 1
  2. Resolution No. 58-12-16 Contracting with the Palm Beach County Supervisor of Elections Office to Conduct the Mayoral Election Tab 2
  3. Resolution No. 59-12-16 Establishing a Mayoral Election Tab 3
  4. Resolution No. 60-12-16 WorldPay Credit Card Processing Agreement Tab 4
- F. **PUBLIC HEARING(S) - RESOLUTION**
5. Resolution No. 52-11-16 Proposing to Designate the Parcels of Real Property located at 1100 Old Dixie Highway, Lake Park, Florida, and Identified by the following Palm Beach County Folio Numbers 36-43-42-20-31-000-0010, 36-43-42-20-31-000-0020, 36-43-42-20-31-000-0030, 36-43-42-20-31-000-0040, 36-43-42-20-31-000-0050, 36-43-42-20-31-002-0000, and 36-43-42-20-31-001-0000 as a Commerce Park Green Reuse Area for Rehabilitation Pursuant to Section 376.80, Florida Statutes. Tab 5
- G. **PUBLIC HEARING(S) - ORDINANCE ON FIRST READING:**  
None
- H. **PUBLIC HEARING(S) - ORDINANCE ON SECOND READING:**  
None
- I. **NEW BUSINESS:**
6. A Request from Bridges of Lake Park to Waive Facility Rental Deposit and Staff Fee for Lake Shore Park Indoor Pavilion Rental on December 14, 2016 Tab 6
  7. The South Florida Southern Rock Festival Event Organizers to Pay for the Damages to Lake Shore Park Tab 7
  8. Commercial Vehicles in Residential Districts Tab 8
  9. Medical Marijuana/Cannabis Discussion Tab 9
  10. Resolution No. 61-12-16 Authorizing Execution of Professional Engineering Services Contract with Craven Thompson & Associates, Inc. for Phases 2,3, and 4 Related to Replacement of the Town's Stormwater Outfall Structures Adjacent to 541 Northlake Boulevard Tab 10
- J. **TOWN ATTORNEY, TOWN MANAGER, COMMISSIONER COMMENTS:**
- K. **ADJOURNMENT:**

**Next Scheduled Regular Commission Meeting will be held on Wednesday, December 21, 2016**



**Minutes**  
**Town of Lake Park, Florida**  
**Regular Commission Meeting**  
**Wednesday, December 7, 2016, 7:05 PM**  
**Town Commission Chamber, 535 Park Avenue**

The Town Commission met for the purpose of a Regular Commission Meeting on Wednesday, December 7, 2016 at 7:05 p.m. Present were Mayor James DuBois, Vice-Mayor Kimberly Glas-Castro, Commissioners Erin Flaherty, Anne Lynch and Michael O'Rourke, Town Manager John O. D'Agostino, Attorney Thomas Baird, and Town Clerk Vivian Mendez.

Town Clerk Mendez performed the roll call and Mayor DuBois led the pledge of allegiance during the CRA Board Meeting.

**SPECIAL PRESENTATIONS/REPORTS**

None

**PUBLIC COMMENT:**

None

**CONSENT AGENDA:**

1. Regular Commission Meeting Minutes of November 16, 2016
2. Resolution No. 58-12-16 Contracting with the Palm Beach County Supervisor of Elections Office to Conduct the Mayoral Election
3. Resolution No. 59-12-16 Establishing the Mayoral Election
4. Resolution No. 60-12-16 WorldPay Credit Card Processing Application

**Motion: Commissioner O'Rourke moved to approve the consent agenda; Commissioner Flaherty seconded the motion.**

Vote on Motion:

Commission Member	Aye	Nay	Other
Commissioner Flaherty	X		
Commissioner Lynch	X		
Commissioner O'Rourke	X		
Vice-Mayor Glas-Castro	X		
Mayor DuBois	X		

Motion passed 5-0.

**PUBLIC HEARING(S) – RESOLUTION**

5. Resolution No. 52-11-16 Proposing to Designate the Parcels of Real Property located at 1100 Old Dixie Highway, Lake Park, Florida, and Identified by the following Palm Beach County Folio Numbers 36-43-42-20-31-000-0010, 36-43-42-20-31-000-0020, 36-43-42-20-31-000-0030, 36-43-42-20-31-000-0040, 36-43-42-20-31-000-0050, 36-43-42-20-31-002-0000, and 36-43-42-20-31-001-0000 as

**a Commerce Park Green Reuse Area for Rehabilitation Pursuant to Section 376.80, Florida Statutes.**

**Open Public Hearing:**

Mayor DuBois opened the public hearing. Town Manager D’Agostino explained that the item had its first reading/hearing on November 16, 2016 and that the current meeting would serve as its second reading/hearing. Vice-Mayor Glas-Castro suggested that Seacoast Utilities be recognized for their efforts.

**Public Comment Opened:**

None

**Public Comment Closed:**

**Motion: Commissioner O’Rourke moved to approve the Resolution 52-11-16; Commissioner Lynch seconded the motion.**

Vote on Motion:

Commission Member	Aye	Nay	Other
Commissioner Flaherty	X		
Commissioner Lynch	X		
Commissioner O’Rourke	X		
Vice-Mayor Glas-Castro	X		
Mayor DuBois	X		

Motion passed 5-0.

**Closed Public Hearing:**

**PUBLIC HEARING(S) – ORDINANCE ON FIRST READING:**

None

**PUBLIC HEARING(S) – ORDINANCE ON SECOND READING:**

None

**NEW BUSINESS:**

**6. A Request from Bridges of Lake Park to Waive Facility Rental Deposit and Staff Fee for Lake Shore Park Indoor Pavilion Rental on December 14, 2016**

Town Manager D’Agostino explained that Bridges of Lake Park had proposed to host a gift giving initiative for its program participants. He explained that the event was scheduled to take place on December 14, 2016 at the Lake Shore Park Pavilion and that the waiver totaled \$350.00.

**Motion: Commissioner Flaherty moved to approve the request from Bridges of Lake Park to waive Facility Rental deposit and staff fee for Lake Shore Park Indoor Pavilion rental on December 14, 2016; Commissioner Lynch seconded the motion.**

Vote on Motion:



Commission Member	Aye	Nay	Other
Commissioner Flaherty	X		
Commissioner Lynch	X		
Commissioner O'Rourke	X		
Vice-Mayor Glas-Castro	X		
Mayor DuBois	X		

Motion passed 5-0

**7. The South Florida Southern Rock Festival Event Organizers to Pay for the Damages to Lake Shore Park.**

Town Manager D'Agostino explained the item (see exhibit "A"). He explained that Southern Promotions & Events held a two-day South Florida Southern Rock Festival on October 1-2, 2016. He explained that prior to the event; the Event Organizers paid the Town a refundable deposit of \$1,800.00 for potential damages to Lake Shore Park and \$400.00 for potential damages to the Indoor Pavilion. He explained that a site survey was performed after the event and it had been determined that the estimated total to repair the damages was \$2,749.64. He requested the permission of the Town Commission to bill the Event Organizers an additional \$549.64 for the damages to Lake Shore Park. Vice-Mayor Glas-Castro questioned the actual cost of the incurred damages. Public Works Director David Hunt explained that the figures reported were estimates that may increase after additional analysis.

**Motion: Vice-Mayor Glas-Castro moved to approve staff to use the deposit for the damages to Lake Shore Park and to invoice the event organizer for additional cost for the damages and if the amount goes unpaid The South Florida Southern Rock Festival Event Organizers would be prohibited from having future events in the Town of Lake Park; Commissioner Flaherty seconded the motion.**

Vote on Motion:

Commission Member	Aye	Nay	Other
Commissioner Flaherty	X		
Commissioner Lynch	X		
Commissioner O'Rourke	X		
Vice-Mayor Glas-Castro	X		
Mayor DuBois	X		

Motion passed 5-0.

**8. Commercial Vehicles in Residential Districts**

Town Manager D'Agostino explained the item (see exhibit "B"). He explained that the Town Code of Ordinances did not prohibit the parking of Commercial Vehicles or Trucks with Commercial Signage. He asked the Commission for guidance on the prohibition of Commercial Vehicles in Residential Districts. Commissioner Flaherty asked for clarification of Commercial Vehicles parked at residences after sunset. Community Development Director Nadia DiTommaso explained that the typical commercial boxed van without an affixed cargo area was not prohibited by ordinance, and that a commercial boxed van with an affixed cargo area was prohibited and classified under the commercial

vehicle definition. Vice-Mayor Glas-Castro questioned if trucks with work equipment were prohibited. Community Development Director DiTommaso answered that trucks with work equipment were not prohibited. Commissioner Lynch asked for clarification of School Buses and Postal Vehicles. Community Development Director DiTommaso explained that buses were defined in section 2 (see exhibit "B"). Community Development Director DiTommaso explained that certain types of passenger vehicles were prohibited per the definition. Commissioner O'Rourke requested clarification of the passenger vans pictured (see exhibit "C"). Vice-Mayor Glas-Castro questioned if a light passenger van similar in size and shape without windows was prohibited. Community Development Director DiTommaso explained that a passenger light van was defined as any motor vehicle having a generally rectangular bulk, which has a carrying capacity of one ton or less was not prohibited. Vice-Mayor Glas-Castro asked if the Code Officers were able to determine a commercial vehicles capacity. Mayor DuBois explained that the capacity of commercial vehicles were listed on the cab of the vehicle as a model designation. Community Development Director DiTommaso explained that due to the lack of language provided in the Town Code, Code Officers are unable to determine if fines for violations should be imposed. Commissioner Flaherty suggested that staff provide the Commission with recommended changes. Commissioner O'Rourke suggested that the changes include a review of the classification of commercial vehicles and consider imposing a fine for multiple vehicles. Town Manager D'Agostino asked if the Commission would permit the parking of one commercial vehicle per property. Community Development Director DiTommaso explained that the Town Code permits the parking of one commercial vehicle per property. She explained that the majority of complaints received by the Community Development Department were in reference to commercial vehicles with lettering and that staff had issues in the determination of what was enforceable due to the language provided in the Town Code. Mayor DuBois suggested that the Code Enforcement Officers provide recommendations to the Commission about their continuous issues as it relates to commercial vehicles.

## **9. Medical Marijuana/Cannabis Discussion**

Town Manager D'Agostino explained the item (see exhibit "D"). Commissioner O'Rourke suggested that the Commission consider the distribution and manufacturers of Medical Marijuana as a revenue source for the Town of Lake Park. Mayor DuBois suggested that the Commission also consider consumption areas per regulation of zoning. Commissioner Lynch read the restrictions per the Florida Department of Health Office of Compassionate Use (see exhibit "D"). Town Manager D'Agostino explained that the State of Florida had approved six dispensing organizations; of the six organizations, three were authorized to manufacture and dispense statewide.

Town Attorney Baird suggested that the Commission began with dispensaries due to their potential impact to the Town; he explained that the State of Florida Legislature has not provided direction as of December 2016. Commissioner O'Rourke asked would the designated areas for dispensaries be limited to the C-4 Zoning District (see map exhibit "D"). Vice-Mayor Glas-Castro suggested that the Commission discuss dispensaries and address cultivation and production in the future. Town Attorney Baird suggested that the Town needed to consult with law enforcement to secure designated dispensary locations.

He explained that legislature was needed in order to continue with the implementation of Medical Marijuana Dispensaries in the Town of Lake Park.

**10. Resolution No. 61-12-16 Authorizing Execution of Professional Engineering Services Contract with Craven Thompson & Associates, Inc. for Phases 2, 3, and 4 Related to Replacement of the Town’s Stormwater Outfall Structures Adjacent to 541 Northlake Boulevard.**

Town Manager D’Agostino explained that Craven Thompson & Associates (CTA) performed landslide and underwater surveys of the existing conditions associated with the replacement of the Town’s stormwater outfall structures for preliminary review by the South Florida Water Management District (SFWMD). He explained that a meeting was held at the SFWMD on August 24, 2016 and that District Staff approved a course of action for the remediation/replacement of the manhole structure, outfall pipe, and embankment restoration. Mayor DuBois asked if Firestone received a discharge permit from SFWMD for the twenty-one inch pipe that was installed. Public Works Director Hunt explained that Firestone did not receive a direct discharge and that Firestone flowed over the embankment. He explained that Firestone engaged a contractor to remediate the embankment and that a smaller outfall pipe was installed in lieu of the original. Mayor DuBois asked if a stormwater drain was installed. Public Works Director Hunt explained that the SFWMD has required Firestone to re-evaluate their site-plan. He explained that Firestone would benefit from the use of the Towns structure and therefore would be asked to become a part of the Towns Stormwater Utility.

**Motion: Commissioner O’Rourke moved to approve Resolution 61-12-16 Authorizing Execution of Professional Engineering Services Contract with Craven Thompson & Associates, Inc. for Phases 2, 3, and 4 Related to Replacement of the Town’s Stormwater Outfall Structures Adjacent to 541 Northlake Boulevard; Commissioner Flaherty seconded the motion.**

Vote on Motion:

Commission Member	Aye	Nay	Other
Commissioner Flaherty	X		
Commissioner Lynch	X		
Commissioner O’Rourke	X		
Vice-Mayor Glas-Castro	X		
Mayor DuBois	X		

Motion passed 5-0.

**TOWN ATTORNEY, TOWN MANAGER, COMMISSIONER COMMENTS:**

**Town Attorney Baird** had no comments

**Town Manager D’Agostino** announced that the Town of Lake Park anticipated applying for a Justice Assistance Grant in the amount of \$6,058.00 for the installation of new security cameras at the Lake Park Public Library. He recognized Administrative Assistant

to the Town Manager Janet Perry and Special Events Director Riunite Franks for their efforts to ensure that the Christmas Tree Lighting Ceremony was successful.

**Commissioner Lynch** announced that The Friends of the Library participated in the Christmas Tree Lighting Ceremony and were pleased with the number of attendees. She recognized Special Events Director Riunite Franks.

**Commissioner O'Rourke** announced that the Town of Lake Park had a contractual agreement with Palm Beach County Fire Rescue. He explained that he had been advised that the exclusive services to the Town of Lake Park had not been maintained and ask Town Manager D'Agostino to investigate the issue.

**Commissioner Flaherty** thanked Town personnel for the Christmas Tree Lighting Ceremony.

**Vice-Mayor Glas-Castro** thanked Town personnel for the Christmas Tree Lighting Ceremony.

**Mayor DuBois** thanked Town personnel for the Christmas Tree Lighting Ceremony. He thanked the Friends of the Library and Library Director Karen Mahnk for hosting a ceremony in remembrance of Late Mayor Desca DuBois. He thanked the Friends of the Library for having a book sale. Commissioner Lynch added that the event was successful and that books were available for purchase at the Library. Mayor DuBois announced that he read to students at Lake Park Elementary School. He announced that there would be a Welcome Reception open to the public for Principal Michelle Fleming on Thursday, January 19, 2016 from 6:00 p.m.-8:00 p.m. at the Town Hall Mirror Ballroom, 535 Park Avenue, Lake Park, FL 33403. He announced that the Chamber of Commerce Government Affairs Committee sought Municipal Legislative Agendas. He announced that he and Town Manager D'Agostino had received plaques of appreciation from Operation Hope. He announced that on December 6, 2016 the Palm Beach Gardens Rotary Club held a Ceremony in observance of Pearl Harbor. He announced that on Friday, December 9, 2016 the transmittal for the U.S. Highway 1 Mixed-Use Application would go before the Treasure Coast Regional Planning Council. He explained that it had received a recommendation for approval and would be listed on their Consent Agenda.



**ADJOURNMENT**

There being no further business to come before the Commission and after a motion to adjourn by Commissioner Flaherty and seconded by Commissioner Lynch, and by unanimous vote, the meeting adjourned at 8:33 p.m.

  
\_\_\_\_\_  
Mayor James DuBois

  
\_\_\_\_\_  
Deputy Town Clerk, Shaquita Edwards

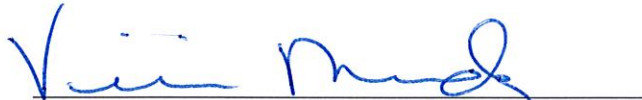
  
\_\_\_\_\_  
Town Clerk, Vivian Mendez, CMC



FLORIDA  
Approved on this 21 of December, 2016

Exhibit "A"



Town of Lake Park Town Commission

Agenda Request Form

Meeting Date: December 7, 2016

Agenda Item No. Tab 7

Agenda Title: THE SOUTH FLORIDA SOUTHERN ROCK FESTIVAL EVENT ORGANIZERS TO PAY FOR DAMAGES TO LAKE SHORE PARK

- Special Presentation/Reports, Board Appointment, Public Hearing Ordinance on Reading, New Business, Consent Agenda, Old Business, Other.

Approved by Town Manager [Signature] Date: 11/22/16
Riunite Franks, Special Events Director
Name/Title

Table with 3 columns: Originating Department (Special Events), Costs (\$0), Attachments (Damage Estimate Form), Advertised (Not Required), Notification details.

Summary Explanation/Background: Southern Promotions & Events held a two-day South Florida Southern Rock Festival on October 1-2, 2016 at Lake Shore Park and Indoor Pavilion. Prior to the event, the organizers paid the Town a total refundable deposit of \$1,800.00 for potential damages to Lake Shore Park and \$400.00 for potential damages to the Indoor Pavilion. After the event, a site survey was performed by staff to assess the damages from the event and it has been determined that the estimated total amount to repair the damages is \$2,749.64. This amount includes material and

labor (**Please see attached damage estimates form for breakdown**). Staff has tried to contact Southern Promotions & Events on several occasions to discuss the damages and repairs. At this time, staff is asking the Town Commission to approve of staff asking Southern Promotions & Events to pay an additional \$549.64 to the Town, which will cover the total repair cost.

**Recommended Motion:** At the Town Commission's discretion based on the information provided.









DAMAGE ESTIMATES  
LAKE SHORE PARK  
SOUTHERN ROCK FESTIVAL  
OCTOBER 1ST 2ND, 2016

DAMAGE LOCATION	DESCRIPTION OF DAMAGE	QUANTITY	ESTIMATED COST TO REPAIR (MATERIAL)	ESTIMATED COST TO REPAIR (LABOR)	
Stage at S.E. corner of park	deep rutting; rake mulch out	15' x 10' x 3" (150 sq.ft.)		\$ 24.34	
S. end of park	deep rutting; damaged sod	18' x 10' (180 sq.ft.)	\$ 52.56	\$ 24.34	
S. end of park	deep rutting; damaged sod deep rutting; rake mulch out	35' x 5' (175 sq.ft.) 50' x 10' x 3" (500 sq.ft.)	\$ 51.10	\$ 48.68	
Ken. of park by Seawall	deep rutting; damaged sod	35' x 3' (105 sq.ft.)	\$ 35.66	\$ 36.51	
BBQ Vendor	trampled sod	10' x 12' (120 sq.ft.)	\$ 35.04	\$ 24.34	
S. driveway entry	deep rutting; damaged sod rutted swale	5' x 3' (15 sq.ft.) sand ruts (labor only)	\$ 4.38	\$ 24.34	



DAMAGE ESTIMATES  
LAKE SHORE PARK  
SOUTHERN ROCK FESTIVAL  
OCTOBER 1ST 2ND, 2016

DAMAGE LOCATION	DESCRIPTION OF DAMAGE	QUANTITY	ESTIMATED COST TO REPAIR (MATERIAL)	ESTIMATED COST TO REPAIR (LABOR)	
N. driveway entry Gate keypad	post knocked over. Need to straighten & reinforce.			\$ 34.95	
N. driveway entry gate keypad	post knocked over. Need to straighten & reinforce.			\$ 34.95	
E. side of Pavilion	trampled sod	20' x 6' (120 sq.ft.)	\$ 35.04	\$ 24.34	
S.E. corner of Tennis Courts	deep rutting; rake mulch out	20' x 15' (300 sq.ft.)	\$	\$ 24.34	
S.E. corner of Tennis Courts	deep rutting; rake mulch out	20' x 12' (240 sq.ft.)	\$	\$ 24.34	
N.E. corner of park	deep rutting; damaged sod	12' x 9' ( 72 sq.ft.)	\$ 21.02	\$ 48.68	

DAMAGE ESTIMATES  
LAKE SHORE PARK  
SOUTHERN ROCK FESTIVAL  
OCTOBER 1ST 2ND, 2016

DAMAGE LOCATION	DESCRIPTION OF DAMAGE	QUANTITY	ESTIMATED COST TO REPAIR (MATERIAL)	ESTIMATED COST TO REPAIR (LABOR)	
N.E. corner of park	deep rutting; rake mulch out	10' x 10' (100 sq.ft.)		\$ 36.51	
N.E. corner Tennis Courts	deep rutting; damaged sod deep rutting; rake mulch out	40' x 12' (480 sq.ft.) 33' x 12' x 3" (396 sq.ft.)	\$ 140.15	\$ 73.02	
N.E. corner Tennis Courts	broken sidewalk (one flag)	5' x 5' x 4"	\$ 168.75	\$ 104.85	
N.E. corner Tennis Courts	deep rutting; damaged sod	66' x 15' (990 sq.ft.)	\$ 289.06	\$ 73.02	
N.E. corner Tennis Courts	deep rutting; damaged sod	130' x 20' (2600 sq.ft.)	\$ 759.15	\$ 73.02	
N. end of park	broken sidewalk (two flags)	10' x 5' x 4"	\$ 337.50	\$ 24.34	



DAMAGE ESTIMATES  
LAKE SHORE PARK  
SOUTHERN ROCK FESTIVAL  
OCTOBER 1ST 2ND, 2016

DAMAGE LOCATION	DESCRIPTION OF DAMAGE	QUANTITY	ESTIMATED COST TO REPAIR (MATERIAL)	ESTIMATED COST TO REPAIR (LABOR)	
N. end of park	deep rutting; damaged sod	21' x 10' (210 sq.ft.)	\$ 61.32		
Misc. materials	3 dump trailer loads of yellow sand for filling and leveling ruts				
<b>TOTAL</b>			<b>\$ 1,990.73</b>	<b>\$ 758.91</b>	



Exhibit "B"

Town of Lake Park Town Commission

Agenda Request Form

Meeting Date: December 7, 2016

Agenda Item No. *Tab 8*

Agenda Title: Commercial vehicles in residential districts.

- SPECIAL PRESENTATION/REPORTS
  - BOARD APPOINTMENT
  - ORDINANCE ON 1<sup>st</sup> READING
  - NEW BUSINESS**
  - OTHER: \_\_\_\_\_
- CONSENT AGENDA
  - OLD BUSINESS

Approved by Town Manager *J.R. Carty* Date: *11/22/16*  
*Nadia Di Tommaso / Community Development Director* *ND*  
 Name/Title

<b>Originating Department:</b>  <b>Community Development</b>	Costs: \$ 0.00 Funding Source: Acct. # <input type="checkbox"/> Finance _____	<b>Attachments:</b>
<b>Advertised:</b> Date: _____ Paper: _____ <input checked="" type="checkbox"/> Not Required	All parties that have an interest in this agenda item must be notified of meeting date and time. The following box must be filled out to be on agenda.	Yes I have notified everyone _____ or Not applicable in this case <i>ND</i> <b>Please initial one.</b>

Summary Explanation/Background:

In a previous Town Commission meeting, the Vice-Mayor requested that the Code for commercial vehicles be revisited. In an effort to bring the discussion full circle and provide for Commission consensus on any code changes that are desired, this item is being brought forward for discussion.

The existing Town Code for commercial vehicles reads the following:

**Sec. 30-35. - Parking of commercial vehicles.**

(a) *Purpose and intent.* It is the intent of this section to preserve the character of the residence districts and to preserve the value of the residential property in the town by prohibiting the parking of commercial vehicles in all residence districts. All other town regulations in conflict with



the requirements of this section are hereby superseded to the extent that the most stringent shall apply.

(b) *Definitions.* As used in this section, the following words, terms and phrases, when used in this section, shall have the meanings ascribed to them in this subsection, unless the context clearly indicates a different meaning:

*Bus* means any motor vehicle, other than a taxicab, designated or used for the transportation of persons or compensation.

*Commercial vehicle* means:

- (1) Any agricultural, construction or industrial equipment;
- (2) Any bus, step van, truck or truck tractor; and/or
- (3) Any taxicab.

*Light van* means any motor vehicle having a generally rectangular bulk, which has a carrying capacity of one ton or less.

*Pickup truck* means any motor vehicle designed primarily for the transportation of property with a permanently attached open cargo or utility box not extending above the vehicle roofline and having a carrying capacity of one ton or less.

*Step van* means any motor vehicle having a generally rectangular bulk, designed and manufactured primarily as a commercial delivery or service truck, and characterized by having sufficient headroom for a person five feet in height to stand upright. The term "step van" shall include, but shall not be limited to, a light van to which an enlarged cargo area has been fitted.

*Taxicab* means any automobile used for the transportation of persons for hire.

*Truck* means any motor vehicle, other than a pickup truck or light van, which is designed primarily for the transportation of property or cargo.

*Truck tractor* means any motor vehicle, other than a pickup truck, which is designed for or equipped with a fifth wheel hitch for drawing semitrailers.

The above prohibition excludes light vans without cargo areas affixed (which is the equivalent of your typical box truck without any cargo area). It also excludes these light vans, regular cars/automobiles (not otherwise prohibited above), or pick-up trucks with commercial signage.

For example, a homeowner who works for an Air Conditioning company or a Landscaping company, driving either a light van (box truck) without a cargo area, or a regular car, or a pick-up truck with commercial signage on the vehicle, would be permitted to park in residential areas.

**Recommended Motion:** For discussion only for possible Commission direction on whether the Town Code should be modified.



REFERENCE to TAB 8

Exhibit "C"

Google

Box Trucks



Sign in

All Shopping Images News Maps More

Settings Tools

chevrolet ford suzuki gmc hino toyota chevy 3500 crew cab dodge ram

SafeSearch  
Get to Google faster. Switch your default search engine to Google.

ford f150   silverado

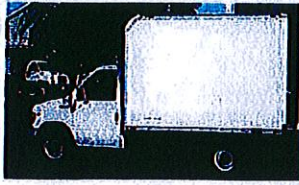

BOX TRUCKS











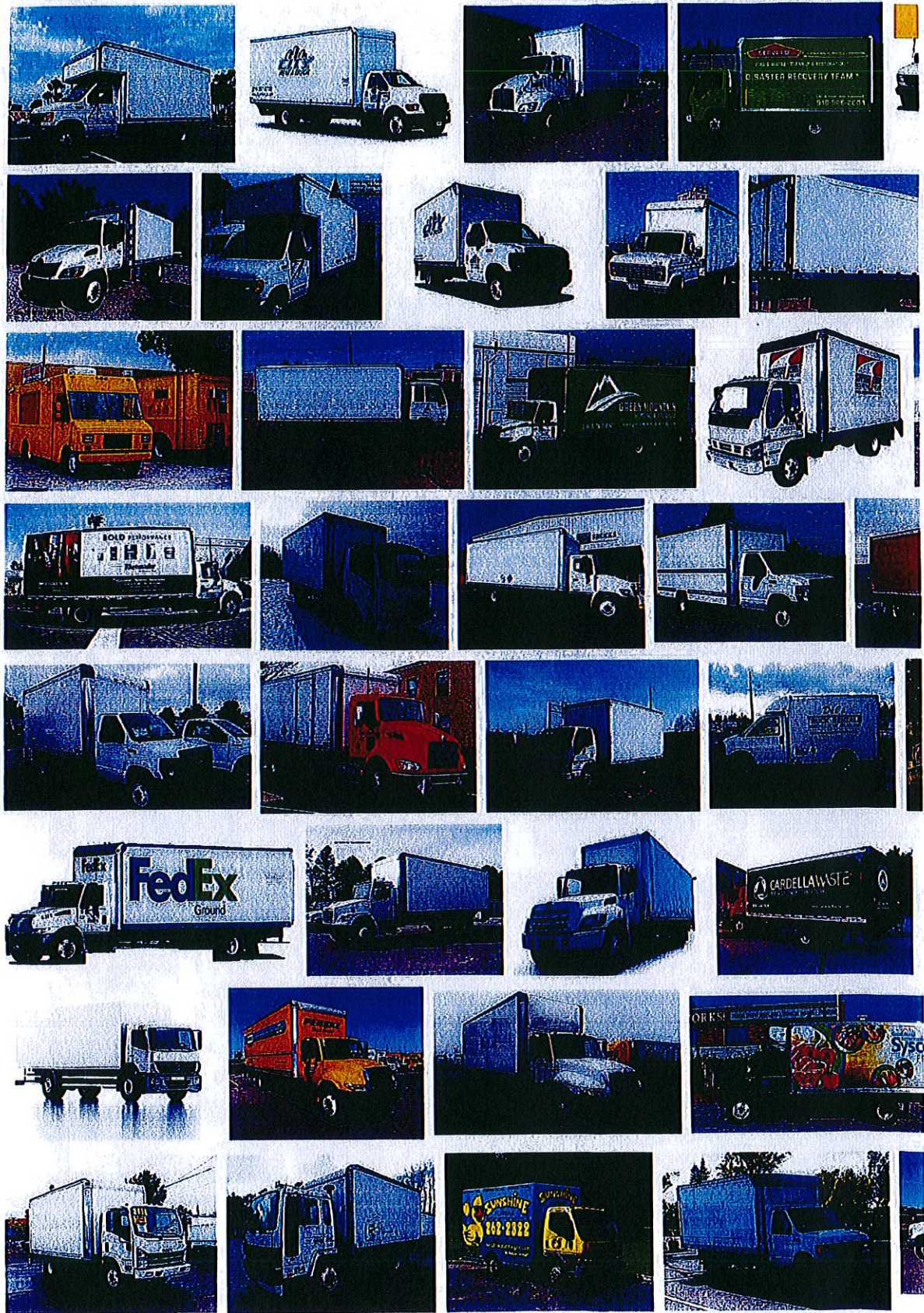





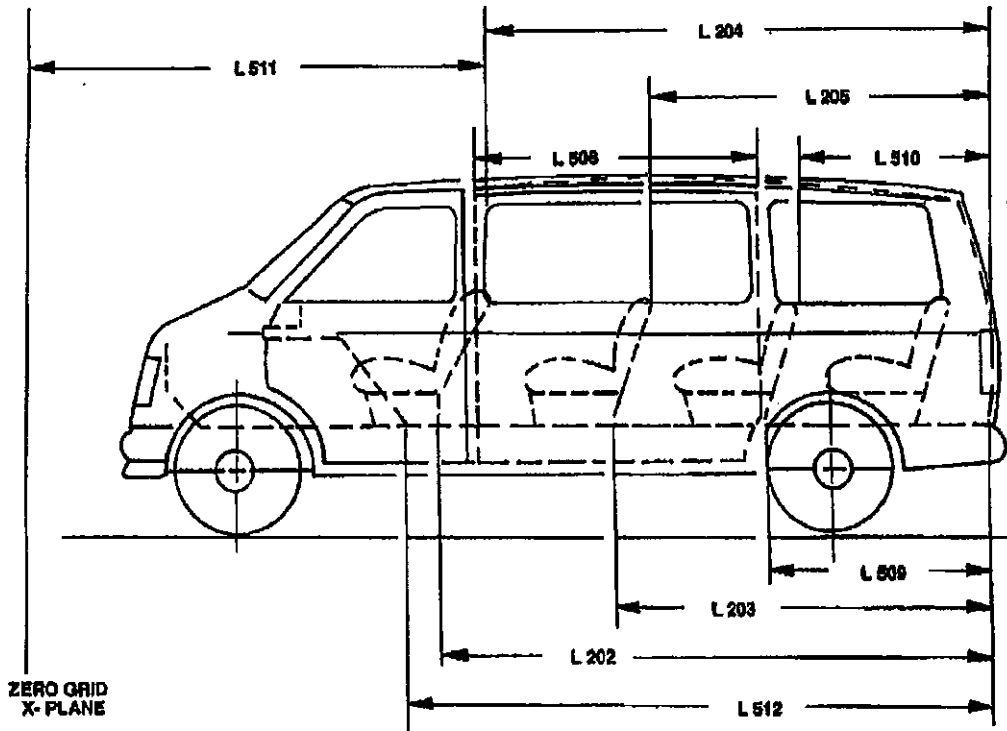
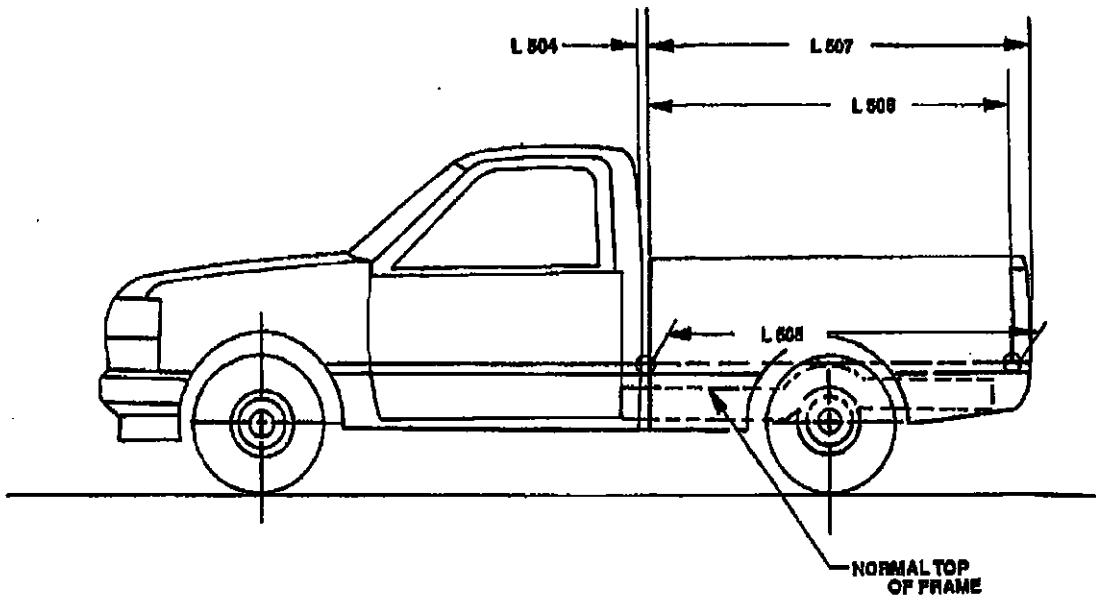

Box Trucks

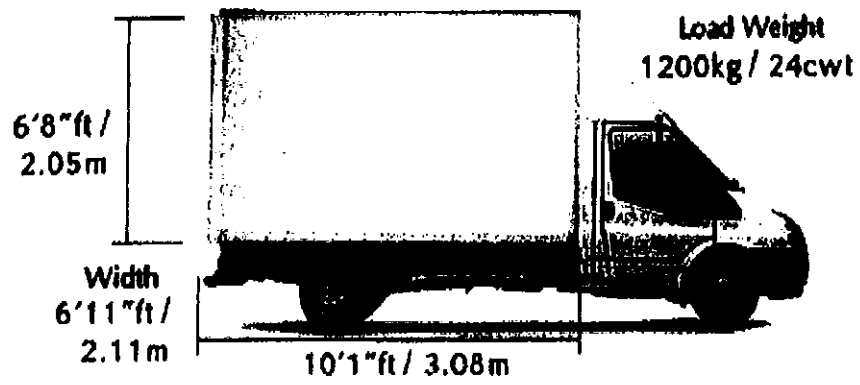



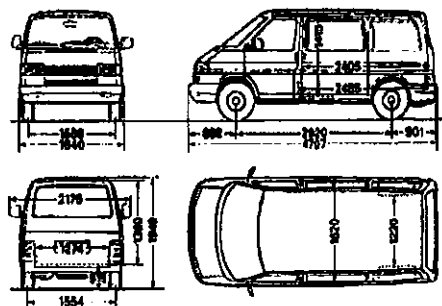



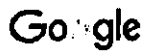

box vans dimensions



Sign In

All

Shopping

Images

News

Videos

More

Settings

Tools

SafeSearch

ford

suzu

uhau

oenske

freightliner

isuzu npr

l150

typical

ryder

door

suzu 16 ft

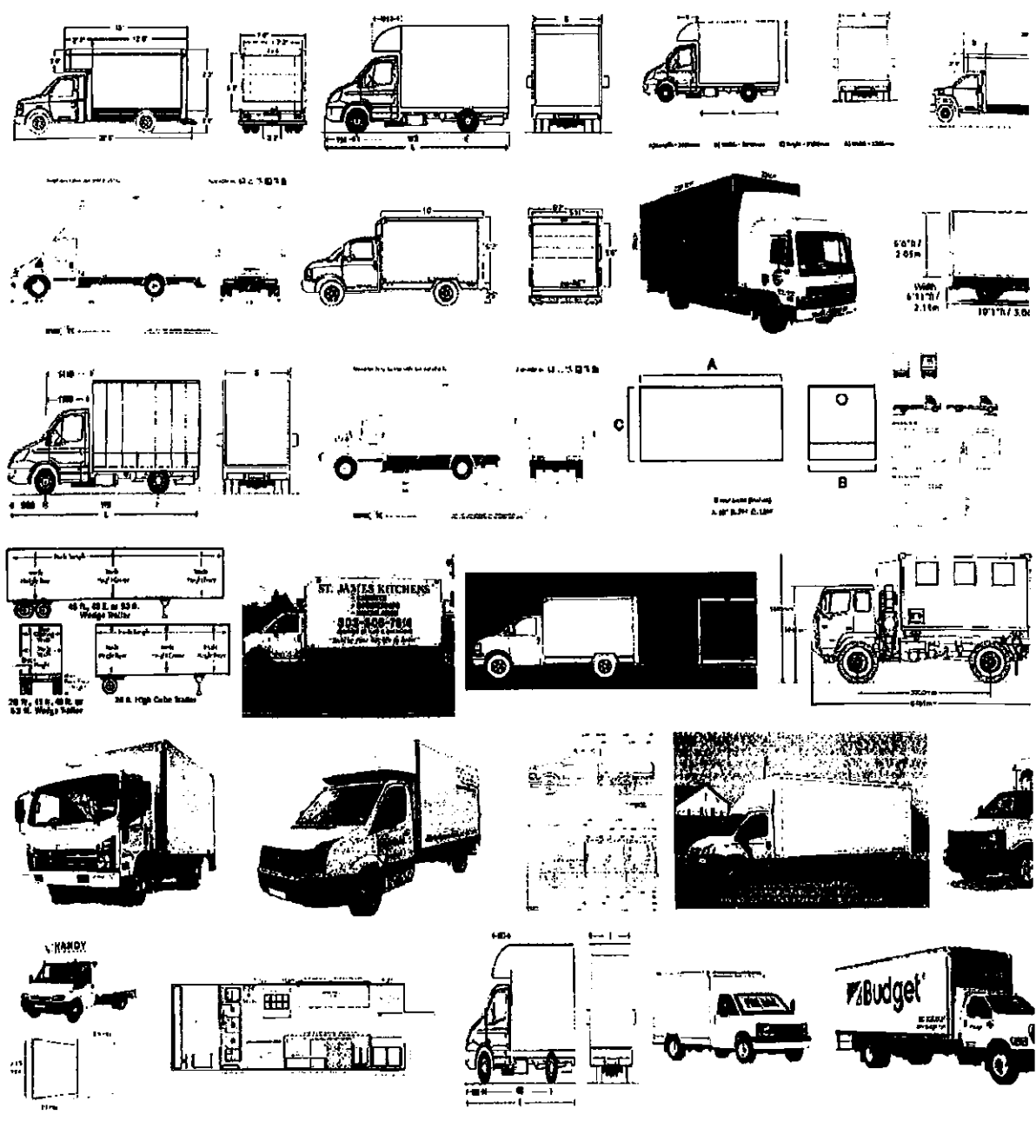

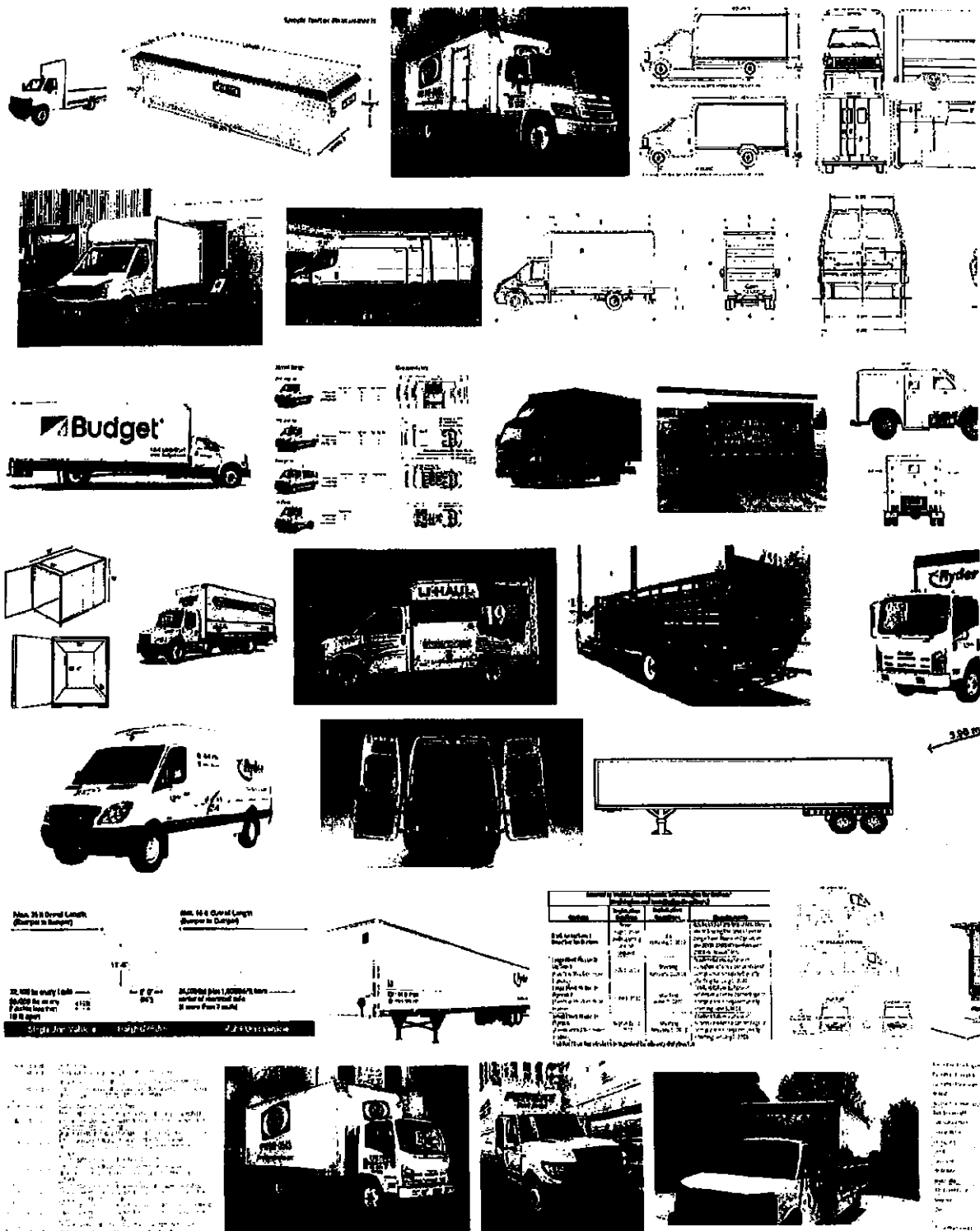

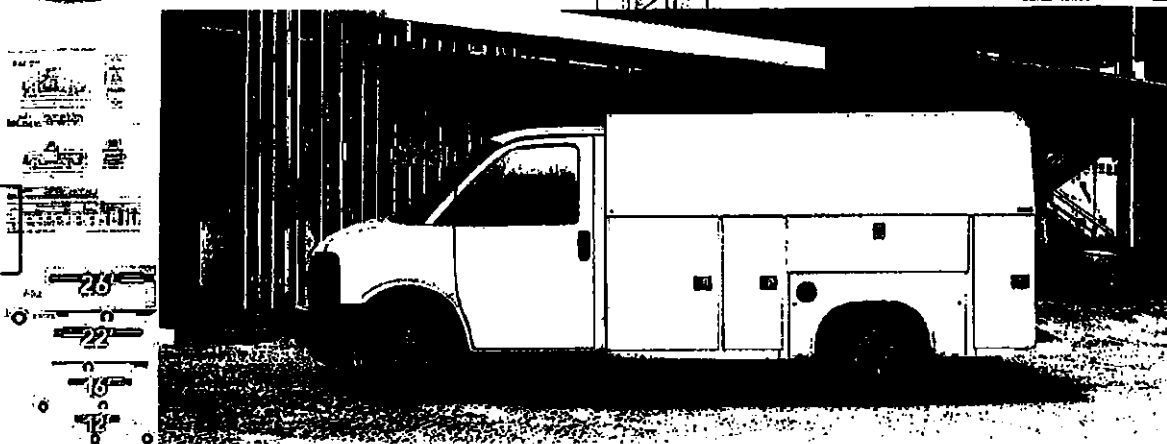
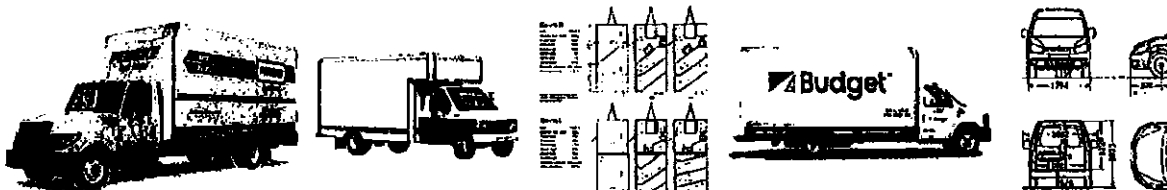

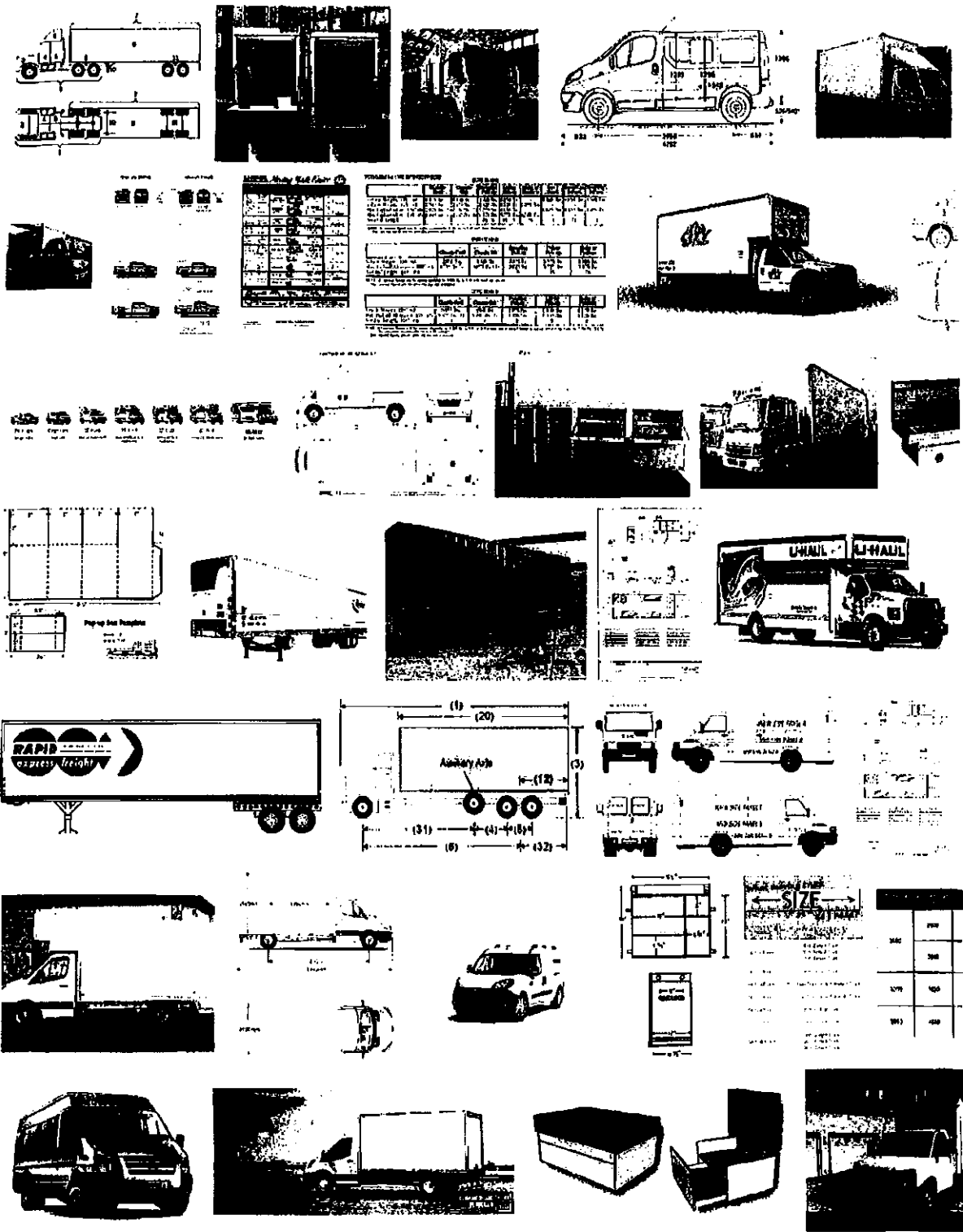



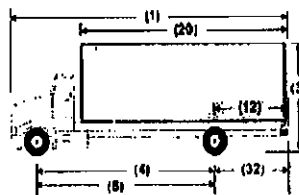
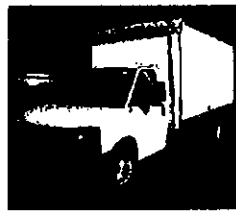
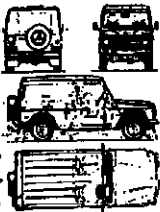
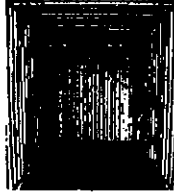
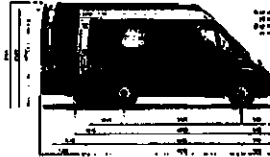
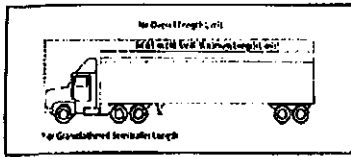

**RENTALS**  
 TRANSIT LUTION  
 City: 191116  
 Year: 191116  
 Fuel Type: Diesel  
 Max Speed: 110 km/h  
 Max Weight: 3000 kg  
 Max Length: 6.00 m  
 Max Width: 2.00 m  
 Max Height: 2.30 m  
 Max Volume: 36.00 m³  
 Fuel Type: Diesel



commercial Vans



Sign in

All Shopping Images

News

Maps

More

Settings

Tools

SafeSearch

ford dodge toyota volkswagen honda mercedes benz usa australia canada malaysia india singapore con

Sponsored



\$461.25  
inlud

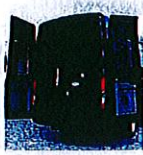

\$2,506.00  
inlud



\$700.00  
Van & Truck Equipment...



\$84.90  
American Van Equipment



\$578.55  
The Rack Warehouse

View all



# COMMERCIAL VANS

















Google

commercial Vans



Sign in

All

Shopping

Images

Videos

News

More

Settings

Tools

SafeSearch

2015 ford transit



COMMERCIAL VANS













# Commercial Vans with demensions - Bing images

Tuesday, December 6, 2016 9:11 AM

Hi (0)John

100

- [Web](#)
- [Images](#)
- [Videos](#)
- [Maps](#)
- [News](#)
- [Explore](#)



## 2014 Ford Transit

The all-new Ford Transit lineup will eventually replace the legendary E-Series, the best-selling vans in history. Adding capability, fuel economy and improved driving dynamics, Transit sets the new standard for full-size commercial vans.

**Can temporary interior design, optimized for productivity.**

**CrewCher™ in-vehicle monitoring system.**

**SYNC™ with available MyFord Touch™.**

**Available in three roof heights: low, medium and high.**

**Fuel filter integrated with driver door for improved security.**

**Auto mirrors, available with power assist and integrated turn signals.**

**Available 3.5-liter EcoBoost™ Premium engine.**

**MyKey™ speed and audio system volume programmability.**

**Rear 12V powerpoint.**

**Available with 180° or 270° opening rear cargo doors.**

**Available Class IV trailer tow package with low/haul mode.**

**Available with single- or dual-rear wheels.**

**Sliding side cargo doors.**

**Up to 500 cubic feet of cargo space.**

**Tire pressure monitoring system.**

**Standard or available extended-length body.**

**Available in two wheelbases.**

**AdvanceTrac™ with Roll Stability Control™.**

**Six-speed automatic transmission.**

**Standard 3.7-liter Ti-VCT V6 engine (offers CNG/LPG prep kit).**

**AVAILABLE 3.2-liter Power Stroke™ Turbo Diesel five-cylinder engine.**

COMMERCIAL VANS

VEHICLE SPECIFICATIONS CHART	
A - Lowered floor length	100"
B - Ramp length	61"
C - Ramp width	33-1/4"
E - Lowered floor width at rear	35"
F - Ground clearance at rear	7-1/2"
G - Interior height in center	59"
H - Entrance height	56"
K - Rear door width	50"
L - Rear clearance at spare tire	41"
M - Rear door open height	84"
N - Vehicle length	198"
O - Flat floor length	65"
P - Floor pan depth - continuous	8-1/2"
R - Wheelbase	121-1/2"
S - Clear distance at jump seat	25"
T - Lowered floor width at front	34-1/2"

Save this image

[See all](#)

[Download](#)

Restricted to wallpaper use only

Image may be subject to copyright. [Learn more.](#)

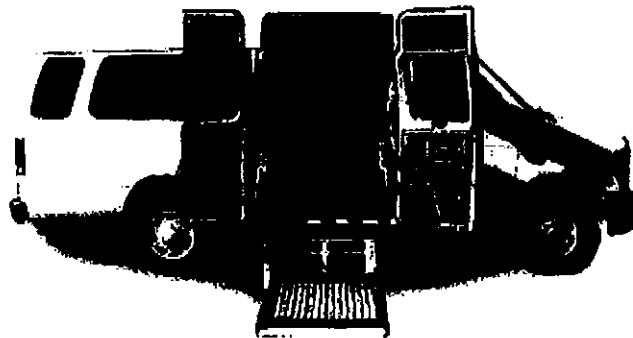

Slideshow paused





Commercial Vans with

2014 Ram ProMaster Dimensions

Ram ProMaster Interior Dimensions

2014 Dodge Ram Dimensions

2014 Dodge Ram ProMaster

2014 Ram ProMaster Van

**PROMASTER**

The 2014 Ram ProMaster is available in:

- 4 Body types, Cargo Van, Glazed Van, Chassis Cab and Out-away
- 3 Wheel bases, 116", 136" and 156"
- 2 Roof heights of 86" and 96"
- 4 Vehicle lengths of 186", 216", 236", and 256"
- Two Engine offerings, 3.0-liter turbo diesel and 3.6-liter gas engine.

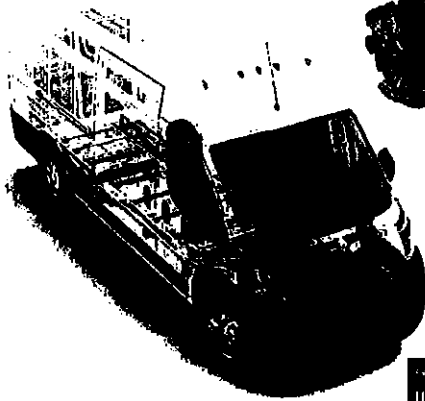

**Cargo Van**

- 116" WB
- 136" WB
- 156" WB
- 186" LWB
- 216" LWB
- 236" LWB
- 256" LWB

**Chassis Cab/Out-away**

- 116" WB
- 136" WB
- 156" WB

3.6-liter Turbo Diesel

3.6-liter Gas Engine

RAM

For more information visit [www.dodgecommercialvehicles.com](http://www.dodgecommercialvehicles.com)  
Chrysler Group Media photo at [alpar.com](http://alpar.com)



View page [alpa-imag.com](http://alpa-imag.com)

710 x 580 jpeg Image may be subject to copyright

2014 Ram ProMaster Dimensions

As with the Ram series, ProMaster is available in three +  
-- [alpar.com](http://alpar.com)



More about this image

20+ pages with it



Exhibit "D"



Town of Lake Park Town Commission

Agenda Request Form

Meeting Date: December 7, 2016

Agenda Item No. Tab 9

Agenda Title: Medical Marijuana/Cannabis Discussion Item.

- Special Presentation/Reports, Board Appointment, Ordinance on 1st Reading, New Business (checked), Other, Consent Agenda, Old Business

Approved by Town Manager [Signature] Date: 11/22/16

Nadia Di Tommaso / Community Development Director [Signature]

Table with 3 columns: Originating Department (Community Development), Costs (\$0.00), Attachments (Florida Department of Health List, Town Zoning Map), Advertised (Not Required), and notification requirements.

Summary Explanation/Background:

Quite some time ago, the Town Commission discussed the incorporation of medical marijuana/cannabis related uses in the Town Code.

While some municipalities throughout Florida have enacted land development regulations (as early as several years ago), other municipalities and Counties (such as Boca Raton, Sarasota, Stuart,



St. Lucie County and Hillsborough County, for example) have decided to place moratoriums on any marijuana/cannabis related uses until which time the State develops regulations for these uses. Since medical marijuana/cannabis recently got approved through the passage of Amendment 2 and in an effort to take a proactive approach since the use may be expanded in the future in the State if approved by an additional amendment, Staff has identified three possible uses for medical marijuana/cannabis and is proposing to create the following in the Town Code **for discussion purposes only this evening, in an effort to gage Commission consensus on how to best move forward:**

**Marijuana/Cannabis Cultivation:** Special exception use only in the CLIC zoning district (Zoning Map enclosed). Operation to be conducted inside a permanent building only.

**Marijuana/Cannabis Dispensaries:** Permitted in the C-4 zoning district (Zoning Map enclosed).

Any other marijuana/cannabis not otherwise listed above would be prohibited in the Town Code. Associated signage, parking, security, State of Florida facility registration confirmation, on-site consumption prohibitions and limited hours of operation are additional regulations that will be included in the proposed Ordinance and are up for discussion this evening as well.

Following tonight's discussion, staff will work with the Town Attorney to prepare a proposed Ordinance that will first be presented to the Planning & Zoning Board at their January 2017 meeting, followed by Town Commission first and second readings in February 2017.

**Recommended Motion:** For discussion only - for Commission direction.

FLORIDA DEPARTMENT OF HEALTH

# Office of Compassionate Use

Low-THC Cannabis & Medical Cannabis



Rick Scott, Governor of the State of Florida  
Celeste Phillip, MD, MPH, State Surgeon General

FloridaHealth.gov

4052 Bald Cypress Way, Bin A-06 • Tallahassee, Florida 32399-3265 • 850-245-4444

September 7, 2016

**Florida's Six Dispensing Organizations:** Approved dispensing organizations are the only businesses allowed to grow or dispense cannabis in Florida. Florida law does not allow for home grow of low-THC or medical cannabis. Presently, three of the six dispensing organizations have received dispensing authorization and are authorized to dispense statewide.

Current physical dispensing locations are in Tallahassee and Clearwater, but dispensing organizations are authorized to deliver statewide. Aside from patients or their legal representatives, dispensing organization employees are the only individuals allowed to transport cannabis. Cannabis cannot be mailed.

Florida's approved dispensing organizations are:

1. \*\*\*Trulieve (Gadsden County)
2. \*\*\*Surterra Therapeutics (Leon & Hillsborough Counties)
3. \*\*\*Modern Health Concepts (Miami-Dade County)
4. \*CHT Medical (Alachua County)
5. \*The Green Solution (Alachua County)
6. \*Knox Medical (Orange County)

*\*Dispensing organization has received cultivation authorization*

*\*\*Dispensing organization has received processing authorization*

*\*\*\*Dispensing organization has received dispensing authorization*

**The Compassionate Use Registry:** The Department of Health's secure, electronic registration system for physicians, patients and legal representatives is available. There are no paper prescriptions for an authorized order of low-THC or medical cannabis.

**Law Enforcement Users:** For access to the registry, please submit a completed [Request for Access to the Compassionate Use Registry Form](#) to the Office of Compassionate Use, 4052 Bald Cypress Way, Tallahassee, FL 32399.

**Restrictions for Use & Administration:** Pursuant to [section 381.986, F.S.](#), patients are prohibited from smoking low-THC or medical cannabis. This means that patients will not have any whole flower as part of their qualified order. Patients cannot use or administer the product on any form of public transportation, in any public place, place of employment if restricted by his or her employer, state correctional institution, on the grounds of a preschool/primary school/secondary school, on a school bus or in a vehicle, aircraft or motorboat.

**For More Information:** If you have questions related to cannabis regulations, please reach out to the Office of Compassionate Use at 850-245-4657 and visit <http://www.floridahealth.gov/OCU>





# Lake Park Zoning Map

City of Palm Beach Gardens

Village of North Palm Beach

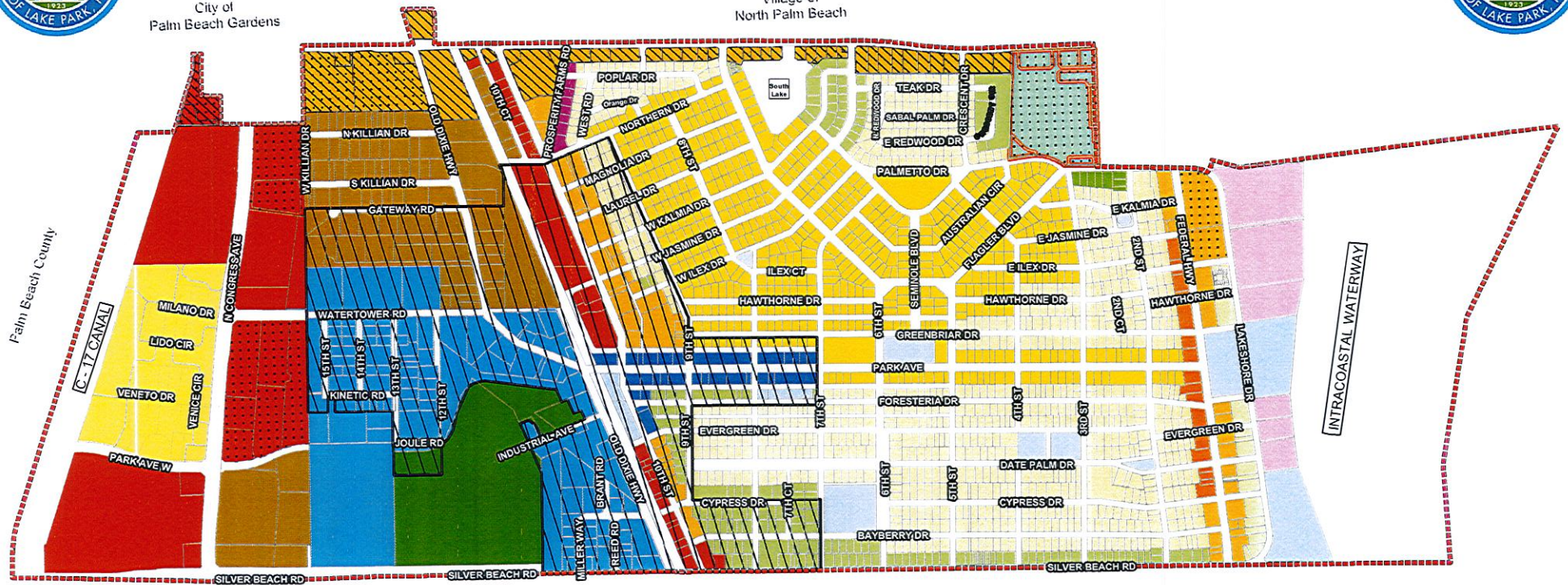

City of Riviera Beach

### Legend

- TOWN BOUNDARY
- C1 BUSINESS DISTRICT
- CLIC CAMPUS LIGHT INDUSTRIAL & COMMERCIAL
- C2 BUSINESS DISTRICT
- CONSERVATION
- C3 BUSINESS DISTRICT
- C4 BUSINESS DISTRICT
- CRA OVERLAY
- NBOZ OVERLAY
- P PUBLIC DISTRICT
- PADD PARK AVENUE DOWNTOWN DISTRICT
- PUD PLANNED UNIT DEVELOPMENT
- R1 SINGLE FAMILY RESIDENCE DISTRICT
- R1A SINGLE FAMILY RESIDENCE DISTRICT
- R1AA RESIDENCE DISTRICT
- R1B TWO FAMILY RESIDENCE DISTRICT
- R2 MULTIPLE FAMILY RESIDENCE DISTRICT
- R2A MULTIPLE FAMILY RESIDENCE DISTRICT
- R3 MULTIPLE FAMILY RESIDENCE DISTRICT
- TND TRADITIONAL NEIGHBORHOOD DEVELOPMENT

Calvin, Giordano & Associates, Inc.  
EXCEPTIONAL SOLUTIONS

Produced and maintained by the CGA  
Geographic Information Systems Services

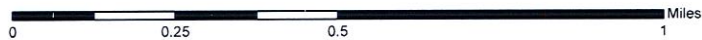

Map Date : 6-28-2016

Nadia Di Tommaso - Director  
Community Development Department  
Town of Lake Park  
535 Park Ave, Lake Park, FL 33403  
561-881-3319 561-881-3323 (fax)  
nditommaso@lakeparkflorida.gov