

Denied

RESOLUTION NO. 15-05-03

A RESOLUTION OF THE TOWN COMMISSION OF THE TOWN OF LAKE PARK, FLORIDA; AUTHORIZING THE TOWN MANAGER TO EXECUTE A CONTRACT FOR THE SALE OF CERTAIN SURPLUS REAL PROPERTY LOCATED AT 900 PARK AVENUE, LAKE PARK, FLORIDA, IN THE AMOUNT OF \$700,000.00 U.S. DOLLARS TO 900 PARK AVENUE LLC, A FLORIDA LIMITED LIABILITY COMPANY TO BE FORMED; DIRECTING THAT THE PROCEEDS DERIVED FROM THE SALE OF THE SUBJECT SURPLUS REAL PROPERTY BE DEPOSITED IN THE GENERAL FUND; DIRECTING THAT THE TOWN'S FIXED ASSET RECORDS BE AMENDED TO REFLECT THE DISPOSAL OF THE SUBJECT REAL PROPERTY; AND PROVIDING AN EFFECTIVE DATE.

WHEREAS, the Town of Lake Park (Town) is a municipal corporation of the State of Florida with such power and authority as has been conferred upon it by the Florida Constitution and Chapter 166, Florida Statutes; and

WHEREAS, the Town is the owner of real properties within the municipal borders of the Town; and

WHEREAS, the Town Commission has determined that certain real property located at 900 Park Avenue ("subject property") which is owned by the Town no longer serves a public purpose; and

WHEREAS, because the subject property no longer serves a public purpose it is considered surplus property of the Town; and

WHEREAS, the Town and its citizens will benefit from the proceeds collected from the sale of surplus real properties; and

WHEREAS, the Town Manager of the Town of Lake Park requested the Town Commission at its meeting of April 3, 2003, to adopt a Resolution authorizing the offer for sale of the subject property and the conditions of the sale; and

WHEREAS, the Town Commission adopted Resolution 15-2002 declaring the subject property as surplus and not needed for public use; and

WHEREAS, the subject property was advertised for sale in the Palm Beach Post for one day with a closing date of March 31, 2003 at 2:00 p.m.;

WHEREAS, 900 Park Avenue LLC, a Florida limited liability company to be formed, submitted the one and only proposal to purchase the subject property; and

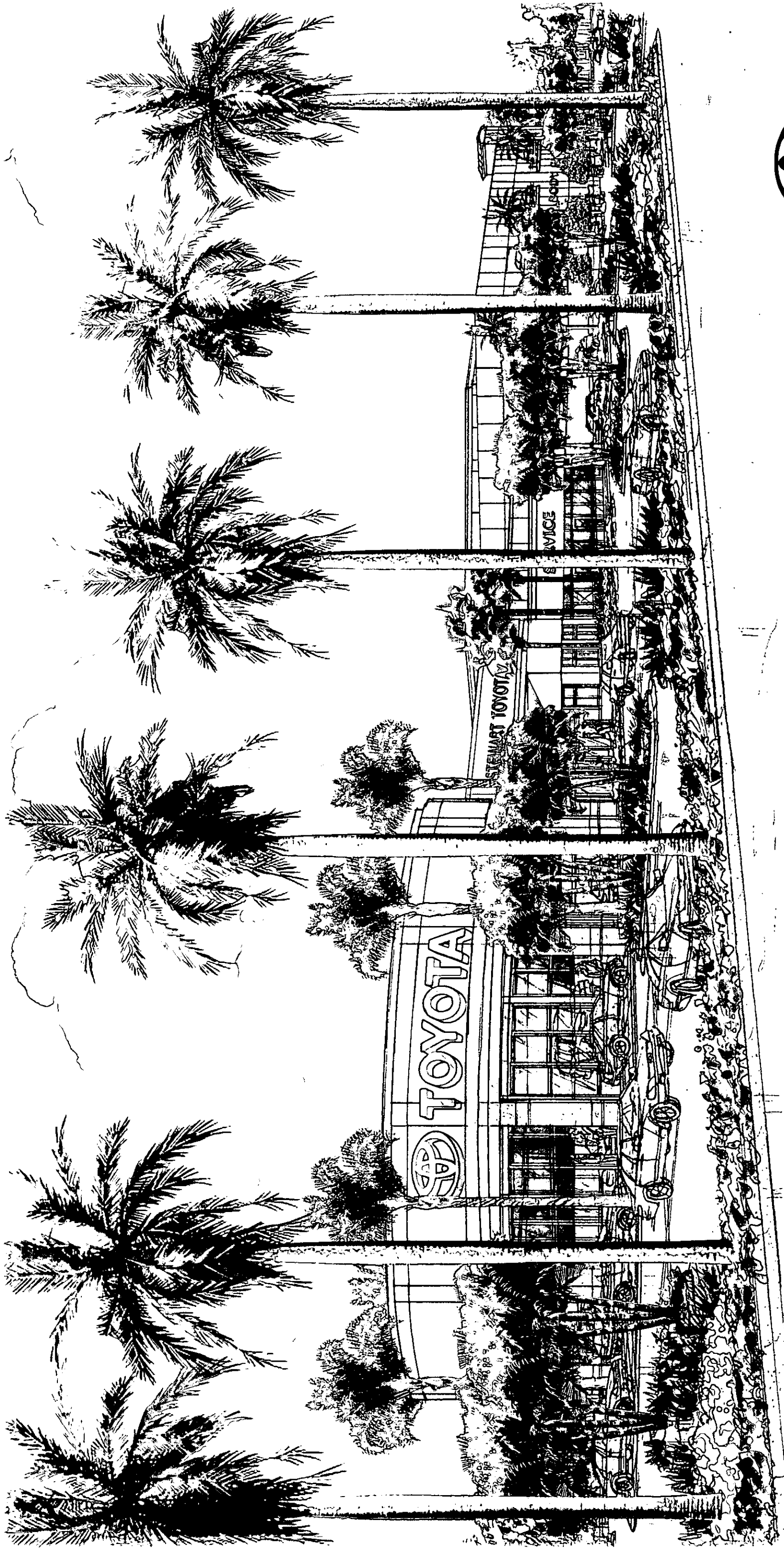

STEWART TOYOTA
LAKE PARK, FLORIDA



OLIVER GLIDDEN SPINA & PARTNERS
ARCHITECTURE • INTERIOR DESIGN, INC.

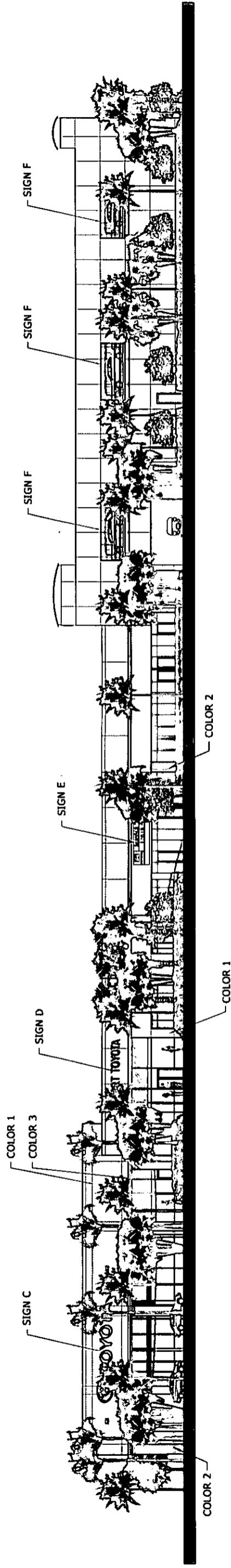

WEST ELEVATION
SCALE: 1/32" = 1'-0"

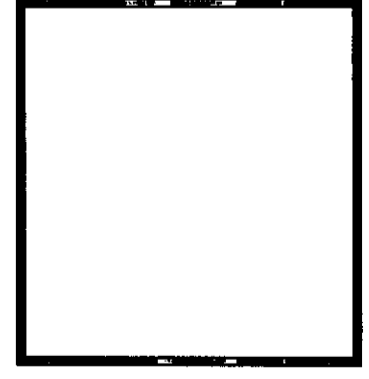

COLOR 1
FIELD COLOR
SW 7009 "PEARLY WHITE"

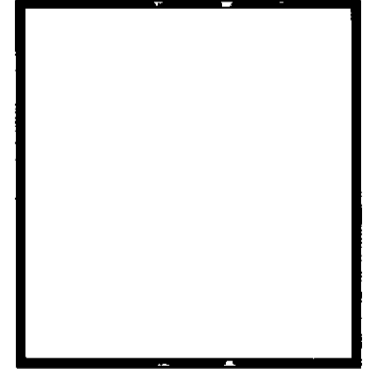

COLOR 2
ACCENT FIELD COLOR (COLUMNS)
SW 7015 "REDROSE GREY"

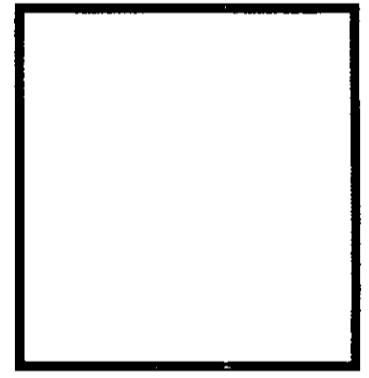

COLOR 3
TOYOTA RED RAL 3001 "SIGNAL RED"
ACCENT BAND

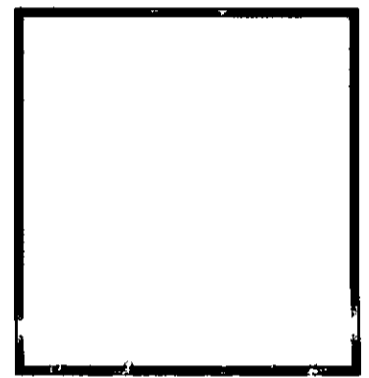

STOREFRONT
CLEAR ANODIZED ALUMINUM

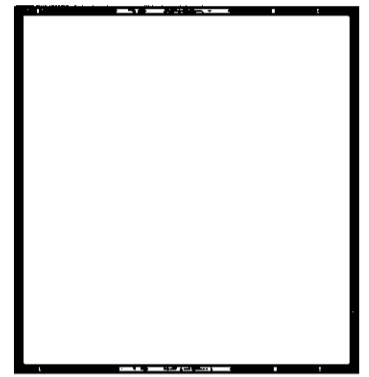

GLASS
1/4" CLEAR TEMPERED GLASS

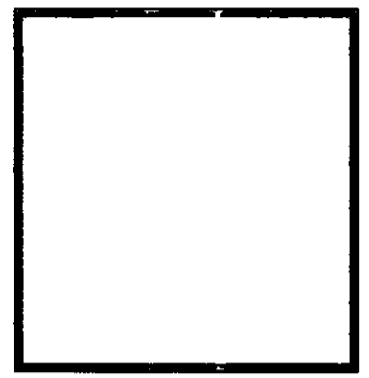

COLOR 4
HOLLOW METAL DOORS, FRAMES, AND
OVERHEAD ROLLING DOORS



OLIVER • GLIDDEN • SPINA & PARTNERS
ARCHITECTURE • INTERIOR DESIGN, INC.



STEWART TOYOTA
LAKE PARK, FLORIDA

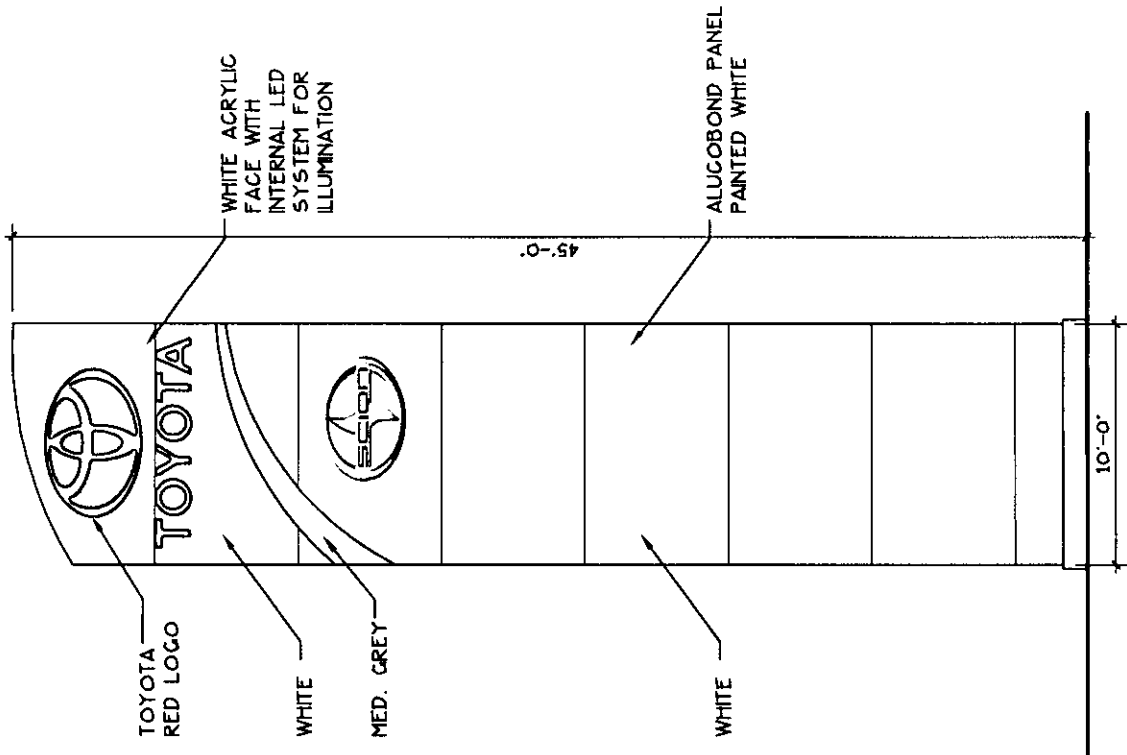

2 SIGN A
SCALE: 1/8"=1'-0"

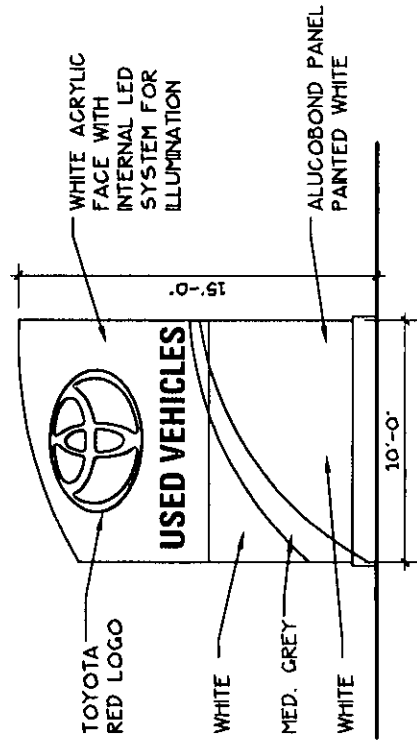
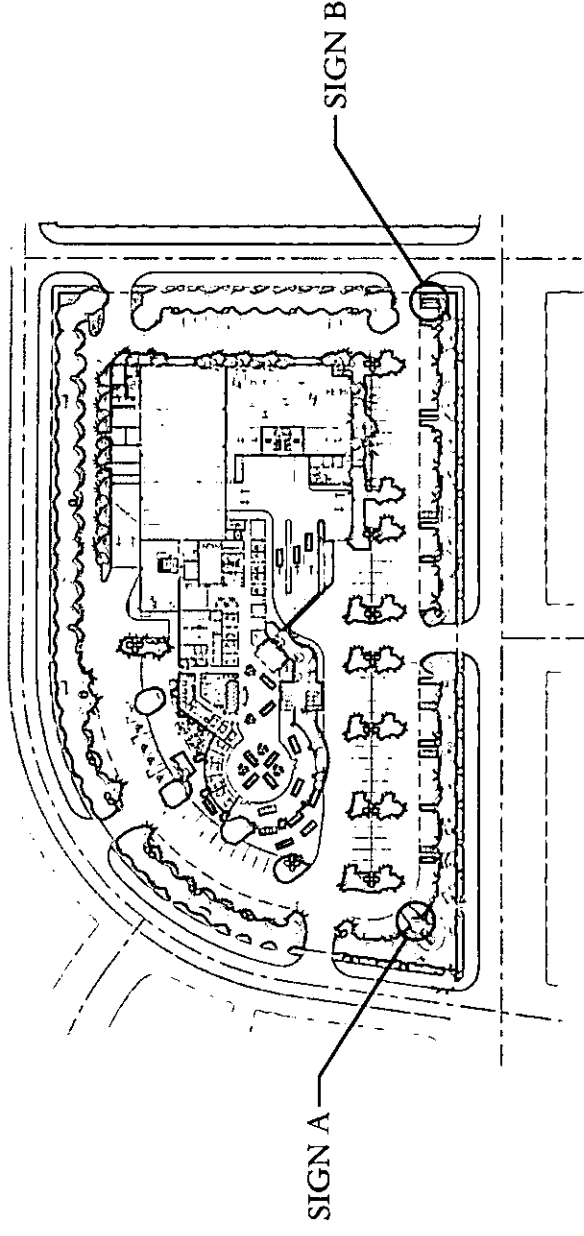

3 SIGN B
SCALE: 1/8"=1'-0"

SITE SIGNAGE



STEWART TOYOTA
LAKE PARK, FLORIDA



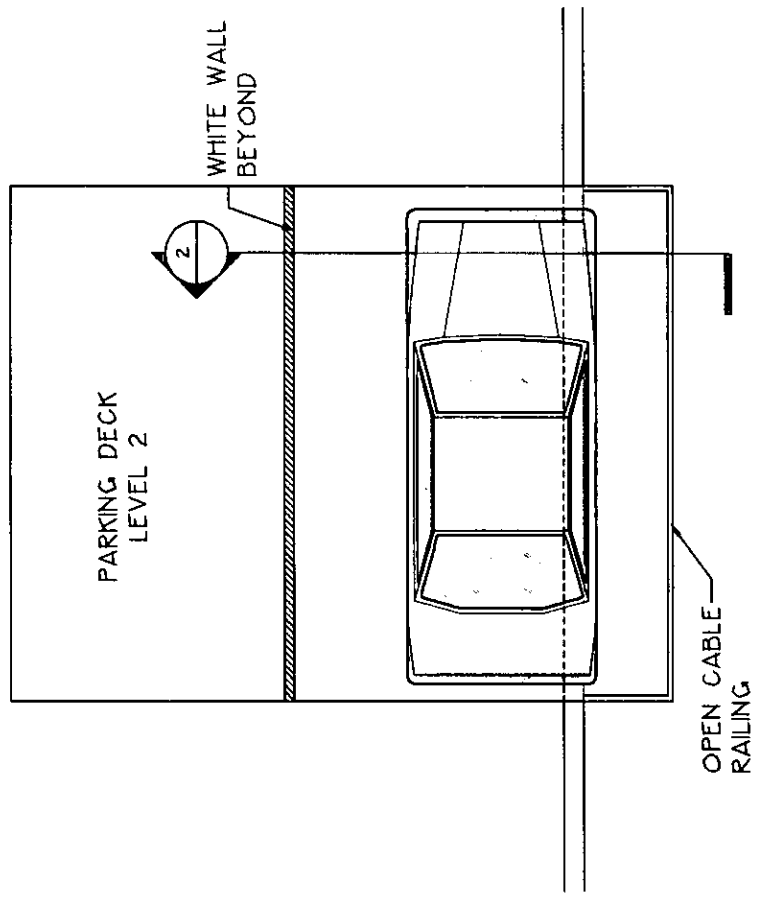

PLAN

VEHICULAR SIGN

1

SCALE: 1" = 10' - 0"

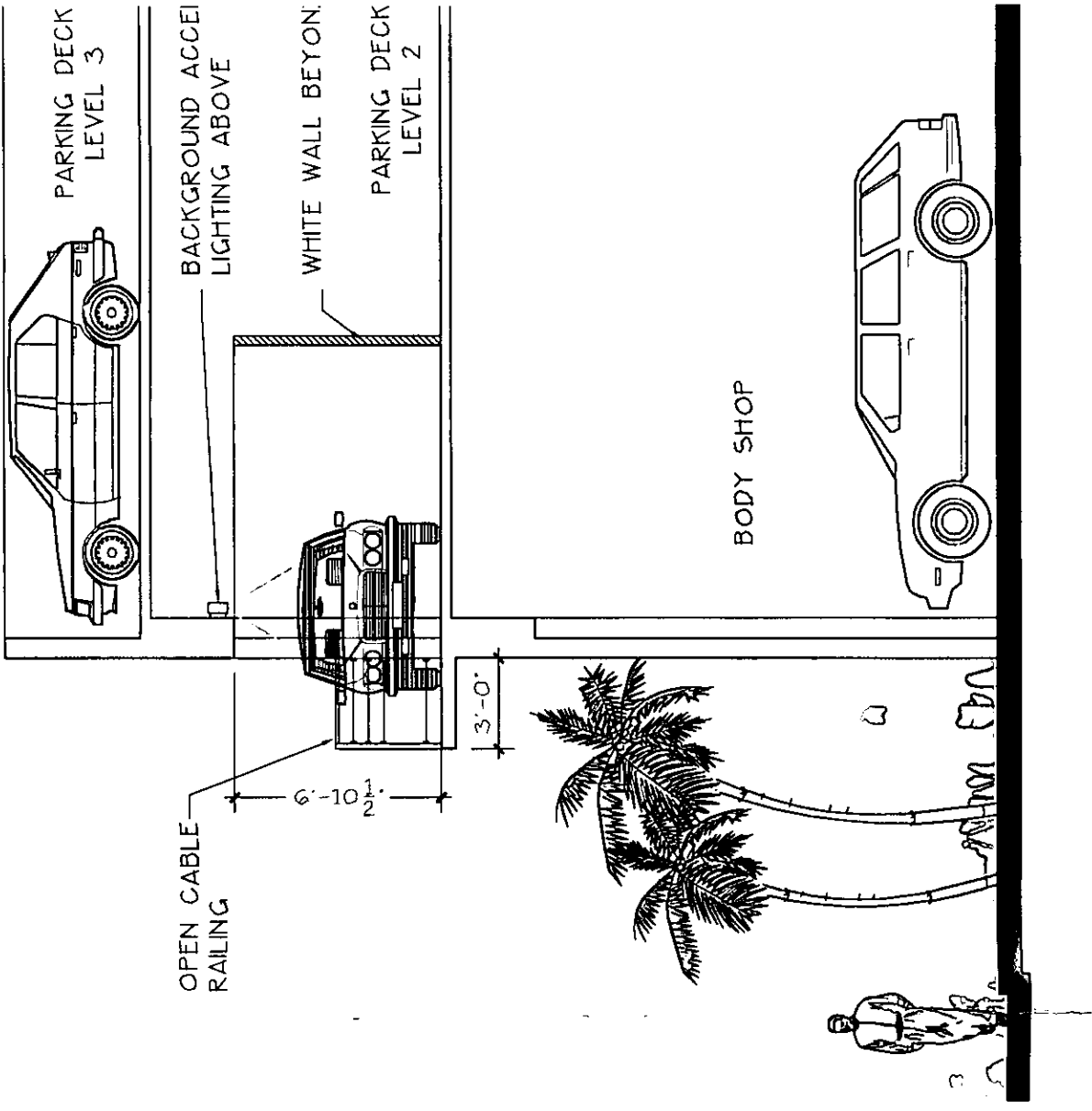

SECTION C

VEHICULAR SIGN

2

SCALE: 1" = 10' - 0"



OLIVER · GLIDDEN · SPINA & PARTNERS
ARCHITECTURE · INTERIOR DESIGN, INC.



STEWART TOYOTA
LAKE PARK, FLORIDA

LAKESHORE DRIVE

JASMINE DRIVE

CASTLEWOOD ROAD

STATE ROAD NO. 5

U.S. HIGHWAY NO. 1 (Federal Highway)

KALMIA DRIVE (AVEUE R BY PLAT)

PALMETTO

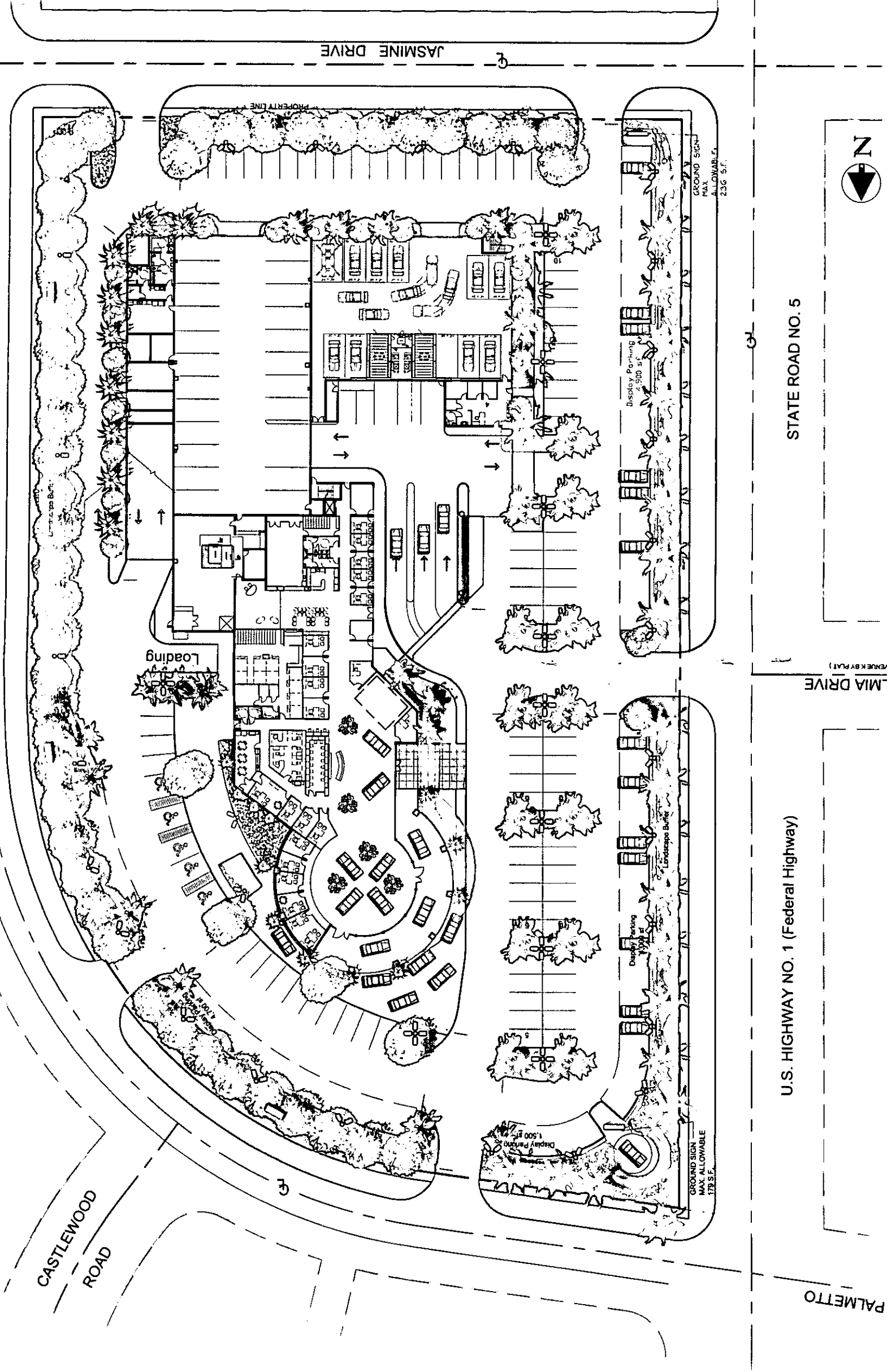

STEWART TOYOTA
LAKE PARK, FLORIDA

Master Site Plan

Scale: 1" = 60'



OLIVER • GLIDDEN • SPINA & PARTNERS
ARCHITECTURE • INTERIOR DESIGN, INC.